

# BWC

*Motion Without Limits®*

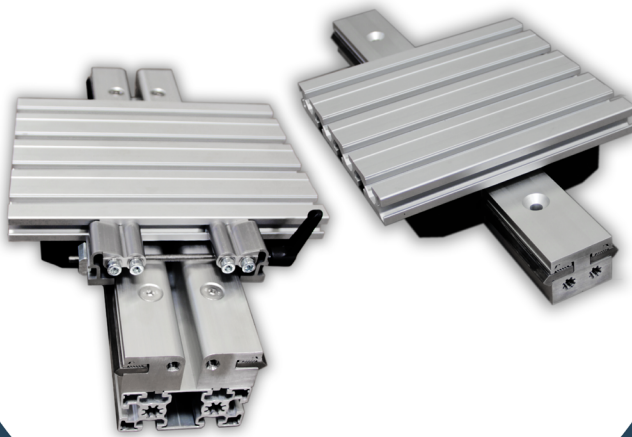

## QUICKTRAK®

**QuickTrak®**, a family of modular linear guide components and sub-assemblies utilizing **DualVee Motion Technology®**, helps manufacturers and automation solution providers assemble machines with motion guidance systems faster and easier with T-nut and T-slot based kits of parts. These products can be cut-to-length and mounted with standard T-nuts onto extrusions, resulting in 70% less downtime, and substantially reduced total cost of ownership.



**BISHOPWISECARVER** GROUP  
A FAMILY OF SOLUTIONS

Located in the historic California steel town of Pittsburg, today's bustling 85,000 square-foot facility is a far cry from the humble Oakland machine shop where the company's founder got his start in the 1950s.

**Bishop-Wisecarver Group** is a woman-owned family of WBENC certified companies who works with manufacturers to engineer, produce, and build custom complex assemblies, linear motion solutions and optimal embedded intelligence systems. Through the integration of our mechanical, electronic, software, control and systems design engineering expertise (mechatronics), 60+ years of experience, and 20,000+ unique clients, we continue to provide a single point of service that results in custom designs, increased efficiencies, and accelerated time to market.

## BWC

**Bishop-Wisecarver Corporation** helps manufacturers and automation solution providers engineer linear and rotary motion solutions. With 60+ years of engineering expertise and manufacturing best practices working with over 20,000 customers, we understand our customers' design and application requirements which enables us to develop unique solutions that typically ship within 2 to 3 weeks. Customers achieve 50% faster time to market, up to 50-75% lower maintenance and installed costs, product differentiation, and longer product life.

{ [www.bwc.com](http://www.bwc.com)  
[info@bwc.com](mailto:info@bwc.com)  
888.580.8272 }

## WRW

**WRW Engineering** helps companies integrate mechanical, electrical and software engineering to deliver custom mechatronic solutions. By understanding the interplay between these three disciplines, we design and develop optimal embedded intelligence systems such as automated flexible testing stations, smart products, and autonomous machines. Through this holistic approach, our customers realize higher production efficiencies, faster time to market, and increased revenues.

{ [www.wrwing.com](http://www.wrwing.com)  
[info@wrwing.com](mailto:info@wrwing.com)  
888.580.8272 }

## BDM

**Black Diamond Manufacturing** is a specialty contract manufacturer of custom complex mechanical sub-assemblies that provides a single source solution from prototype to full production, resulting in lower overall costs. Offerings include product lifecycle services such as prototyping, kitting, support machining, and full scale production with the ability to manage customer supply chains and hold consignment inventory. With 60+ years of in-house manufacturing experiences and capabilities, our clients experience upward of 35% reduction in manufacturing and labor costs.

{ [www.blackdiamondmfg.com](http://www.blackdiamondmfg.com)  
[info@blackdiamondmfg.com](mailto:info@blackdiamondmfg.com)  
888.580.8272 }

**CORPORATE HEADQUARTERS**  
Bishop-Wisecarver Group  
2104 Martin Way  
Pittsburg, CA 94565-5027  
888.580.8272

**FIND US ONLINE**  
WEBSITE: [www.bwc.com](http://www.bwc.com)  
BLOG: [www.bwcnews.blogspot.com](http://www.bwcnews.blogspot.com)  
TWITTER: @BWCnews  
YOUTUBE: [www.youtube.com/BishopWisecarver](http://www.youtube.com/BishopWisecarver)

# APPLICATION DATA SHEET

Company Name: \_\_\_\_\_

Contact Name: \_\_\_\_\_

Address: \_\_\_\_\_

City: \_\_\_\_\_ State: \_\_\_\_\_ Zip Code: \_\_\_\_\_

Phone: \_\_\_\_\_ Fax: \_\_\_\_\_

E-Mail: \_\_\_\_\_

I would like to receive the monthly e-newsletter (please check):  Y  N

System Orientation: \_\_\_\_\_  horizontal  vertical

Load: \_\_\_\_\_  lbs  N

Stroke Length: \_\_\_\_\_  in  m

Velocity: \_\_\_\_\_  in/s  m/s

Accel/Decel: \_\_\_\_\_  in/s<sup>2</sup>  m/s<sup>2</sup>

Linear Accuracy: \_\_\_\_\_  in/ft  mm/m

Repeatability: \_\_\_\_\_  in  m

Duty Cycle: \_\_\_\_\_  in/day  m/day

Environment: \_\_\_\_\_

Temperature: \_\_\_\_\_  °F  °C

Additional Forces: \_\_\_\_\_  lbs  N

Application Description: \_\_\_\_\_  
\_\_\_\_\_  
\_\_\_\_\_  
\_\_\_\_\_

Design Challenge/Issues to Solve: \_\_\_\_\_  
\_\_\_\_\_  
\_\_\_\_\_

Current Design Strengths to be Reinforced/Maximized: \_\_\_\_\_  
\_\_\_\_\_  
\_\_\_\_\_

Market/Competitive Advantage Opportunities to be Gained: \_\_\_\_\_  
\_\_\_\_\_  
\_\_\_\_\_

Expected Volume: \_\_\_\_\_ Deadline: \_\_\_\_\_

Please send this form, along with a drawing example, to  
fax **925.439.5931** or email **info@bwc.com**

## Table of CONTENTS

**CONTENTS**

Introduction..... 1  
 Product Overview..... 2

**QuickTrak Double-Edge (QTD)**

Systems..... 3  
 Track Assemblies..... 4  
 Wheel Mounting Kits..... 5  
 Brake Kits..... 5

Application Example..... 6

**QuickTrak Single-Edge (QTS)**

Systems..... 7  
 Track Assemblies..... 8  
 Wheel Mounting Kits..... 9  
 Brake Kits..... 9

Wheel Plate Extrusions..... 10

How to Order..... 11  
 Product Summary..... 12

## Why choose QUICKTRAK®

- Customizable solution
- Compatible with T-slot aluminum extrusions
- Quick design and installation
- Expedited assembly time
- Very durable



# Introduction

Based on **DualVee Motion Technology®**, the **QuickTrak®** product line from Bishop-Wisecarver is a 90° vee guide wheel based linear motion platform which can be utilized across many industries and unique applications, enabling smooth and reliable motion in any environment from very clean to heavily debris-laden.

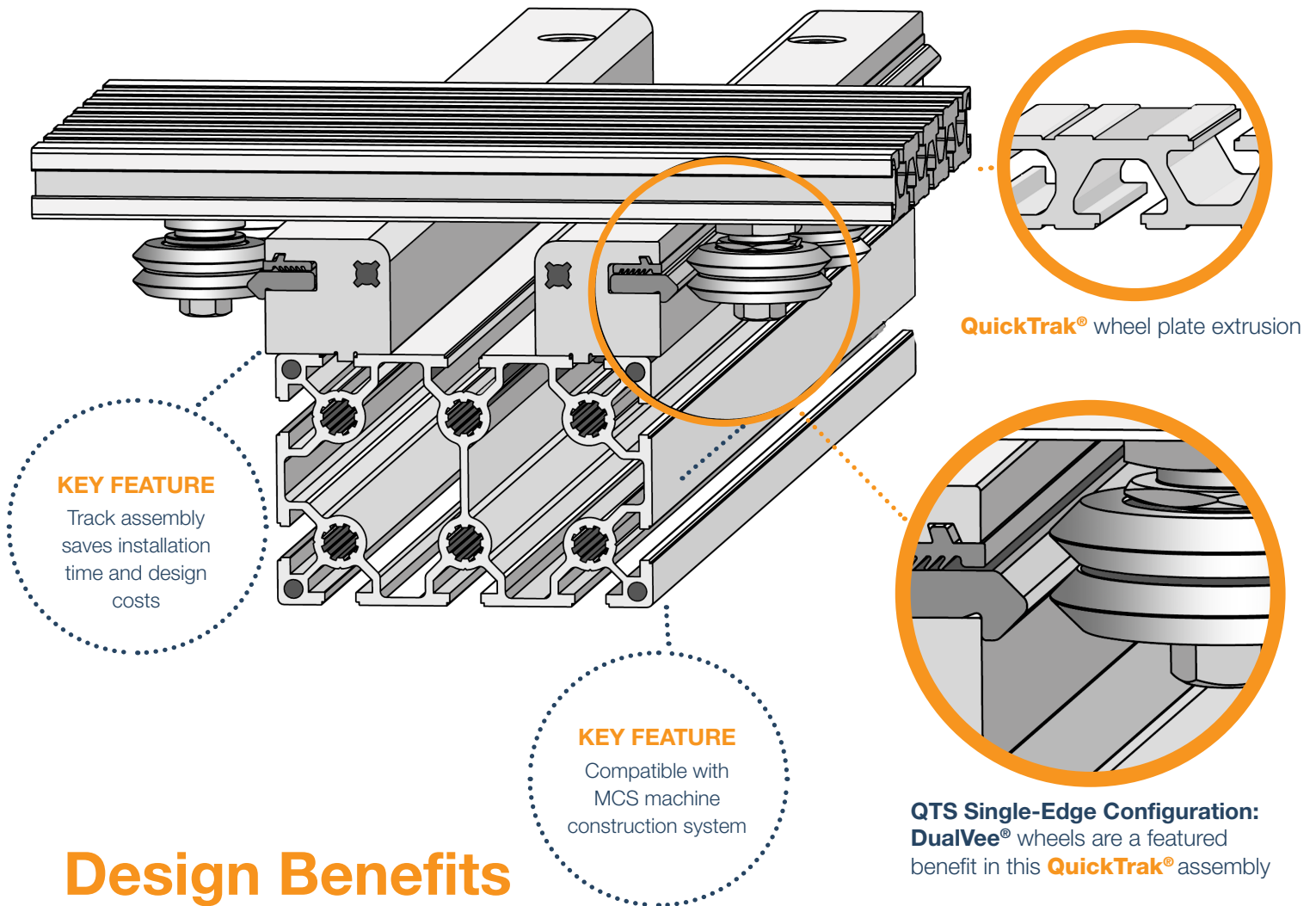

## Design Benefits

- Systems are built from kits of modular components and sub-assemblies, enabling quick design and installation on finished products and production equipment
- Mount to T-slot aluminum extrusions with minimal machine shop support and assemble with only simple hand tools
- Modular extrusion based wheel plate assemblies with customizable width and wheel span
- Track assembly is mounted with standard fasteners onto extrusions
- Components can be customized for specific end-user application requirements
- Based on **DualVee®** guide wheels and vee-edge track in size 2 and size 3

# Product Overview

How to specify a **QuickTrak®** linear guidance system

**QuickTrak®** is available as a full assembly and can be supplied with user specified modifications and configurations.

**QuickTrak®** can also be supplied as a kit of parts for users to assemble.

[ how to order ]

ASSEMBLED OR AS A KIT			
DOUBLE-EDGE (QTD)		SINGLE-EDGE (QTS)	
ASSEMBLED OPTIONS:	SELF-ASSEMBLY KIT CONTAINS:	ASSEMBLED OPTIONS:	SELF-ASSEMBLY KIT CONTAINS:
With Brake	Track Assemblies	Customized Assembly	Track Assemblies
Without Brake	Wheel Plate Extrusion		Wheel Plate Extrusion
Customized Assembly	Wheel Mount Kit		Wheel Mount Kit
	Brake Kit		Brake Kit
	Components		Components

Available in two sizes utilizing **DualVee®** guide wheels in sizes 2 and 3

## QuickTrak® Features

- Anodized 6063 aluminum compact extrusion
- Permanently assembled linear guide surfaces in the form of **DualVee®** track made of AISI 1045 carbon steel hardened to 53 HRC minimum
- Double-edge track assemblies are a fixed width but single-edge track assemblies can span wider distances
- Single-edge track assemblies can be mounted to T-slot aluminum framing or slotted surface (can be quickly aligned using the extruded locating feature on the bottom surface of the track assembly)
- Length of the track assembly is user specified and can be supplied in any length up to 6 meters long (no joints in the track running surfaces)
- Wheel mounting kits contain snap-fit wheel covers with lubricated wiper foam, and mounting hardware
- Brake kits contain an adjustment handle, brake calipers, and mounting hardware
- Low cost T-slot aluminum extrusion based wheel plates designed for rapid assembly

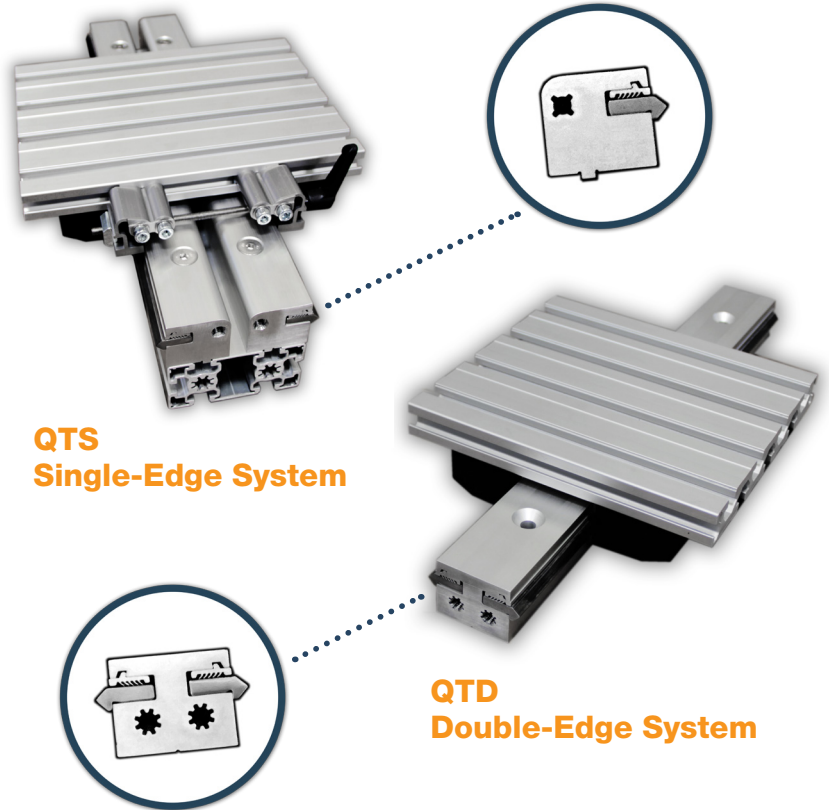

# Double-Edge Systems

## System Specifications

- Basic load capacity of double-edge QTD2 in the wheels' axial direction is 564 lbf and 1192 lbf radially with an L10 rated life of 87km of travel
- Basic load capacity of double-edge QTD3 in the wheels' axial direction is 1528 lbf and 2652 lbf radially with an L10 rated life of 130km of travel
- Utilizing **DualVee®** wheels and track sizes 2 and 3
- See the complete **DualVee Motion Technology®** catalog for further wheel and track details
- Mounts to T-slot aluminum extrusion or flat surface
- Available with optional brake kits

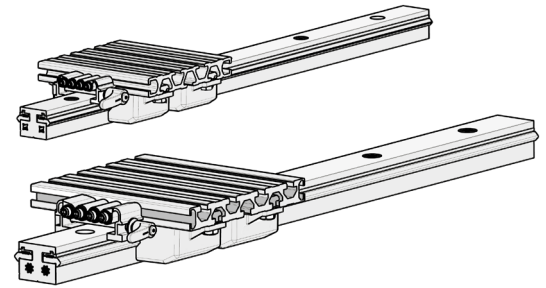

PART NUMBER	DESCRIPTION	UNITS
QTD2 _____*	System assembly – <b>QuickTrak®</b> Double-Edge Size 2	ea
QTD3 _____*	System assembly – <b>QuickTrak®</b> Double-Edge Size 3	ea

\* Final part number is assigned by BWC; please call

DESCRIPTION			QTD2, SIZE 2		QTD3, SIZE 3	
			(inches)	(millimeters)	(inches)	(millimeters)
WHEEL PLATE & BRAKE DIMENSIONS	Wheel Spacing Width	A	2.634	66.9	3.771	95.78
	Wheel Plate Width (Min.)	B	5.354	136	7.717	196
	Mounting Surface to Wheel Cover	C	0.066	1.67	0.111	2.81
	Wheel Plate Length	D	5.118	130	7.087	180
	Wheel Spacing Length	E	2.953	75	3.543	90
	Wheel Plate Height	F	2.000	50.79	2.553	64.85
	Wheel Plate T-Slot to End	G	1.821	46.25	0.886	22.5
	Wheel Plate T-Slot Spacing	H	1.476	37.5	1.772	45
	Wheel Plate Thickness	J	0.738	18.75	0.886	22.5
	Brake Kit Length	K	1.260	32	1.730	43.95
	Brake Kit Maximum Length	M	2.284	58.01	2.475	62.87
	Brake Kit Width	N	4.026	102.26	5.207	132.26
	Mounting Hole to Brake Handle	P	2.432	61.78	3.087	78.41
TRACK	Track Assembly Length	L	TRAVEL + D + K		TRAVEL + D + K	
	Track Assembly Width	W	1.260	32	1.772	45

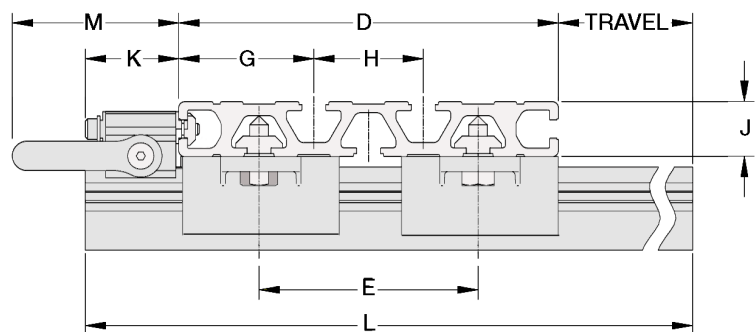
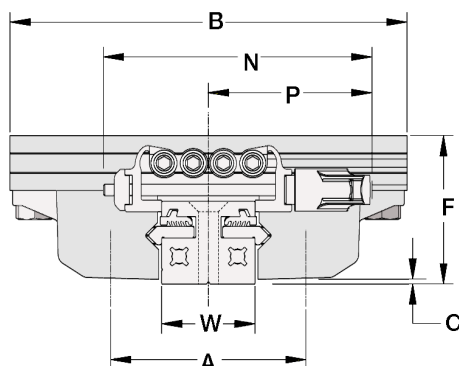

# Double-Edge Track Assemblies

## Product Features

- Mount track over any T-slot aluminum extrusion or flat surface quickly and easily with simple hand tools and common fasteners
  - Size 2 designed for 8mm T-slots and M6 flat head screws
  - Size 3 designed for 10mm T-slots and M8 flat head screws
- Inherently parallel track surfaces eliminate alignment issues
- Patented track clamp wedge with flexible fingers permanently holding the steel track without adhesives
- Made from clear anodized 6063 aluminum with hardened and polished AISI 1045 carbon steel **DualVee®** track (53 HRc minimum)
- Supplied permanently assembled and cut to length up to 6m maximum
- Extruded end holes can be threaded

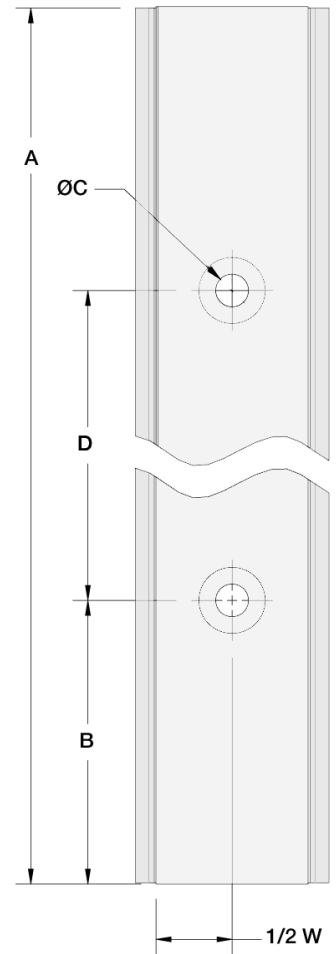
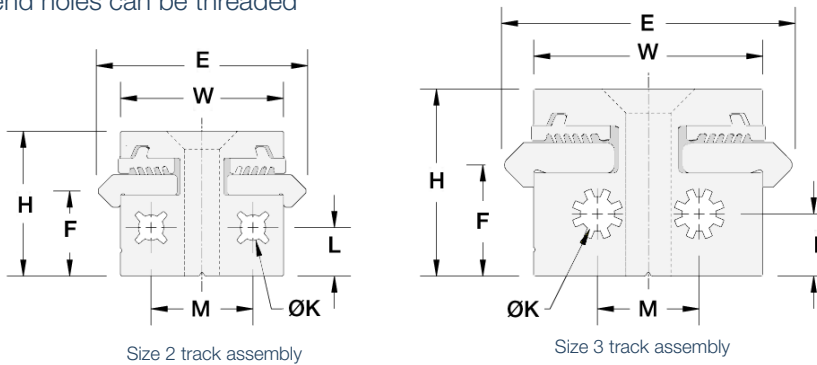

PART NUMBER	DESCRIPTION	UNITS
QTD2TA	Track Assembly — <b>QuickTrak®</b> Double-Edge Size 2	meter
SHFLM6X35SS	Mounting Screw — Flat Head M6 x 35 mm stainless	ea
12421026	Mounting T-nut — M6 thread for 8mm T-slot	ea
QTD3TA	Track Assembly — <b>QuickTrak®</b> Double-Edge Size 3	meter
SHFLM8X45SS	Mounting Screw — Flat Head M8 x 45 mm stainless	ea
12421002	Mounting T-nut — M8 thread for 10mm T-slot	ea

DESCRIPTION			QTD2TA—SIZE 2		QTD3TA—SIZE 3	
			(inches)	(millimeters)	(inches)	(millimeters)
TRACK ASSEMBLY DIMENSIONS	Track Assembly Length	A	Specify length per meter up to 6.0 maximum			
	Track End Spacing	B	$(A\text{-# of } D \text{ spaces} \times D) / 2$		$(A\text{-# of } D \text{ spaces} \times D) / 2$	
	Track Assembly Mounting Hole Diameter	C	0.272	6.9	0.348	8.84
	Track Assembly Mounting Hole Spacing	D	4.724	120	5.906	150
	Vee Spacing Width	E	1.634	41.5	2.272	57.71
	Vee Spacing Height	F	0.656	16.66	0.857	21.77
	Track Assembly Width	W	1.260	32	1.772	45
	Track Assembly Height	H	1.118	28.4	1.444	36.68
	Track Assembly End Hole Diameter	K	0.197	5	0.266	6.8
	Track Assembly End Hole Height	L	0.374	9.5	0.480	12.19
	Track Assembly End Hole Width	M	0.787	20	0.787	20

# Double-Edge Wheel Mounting Kits

## Product Features

- Kits contain all parts needed to assemble your own wheel plate onto T-slot aluminum extrusions (recommended 2 kits per assembly)
- Insert T-bar into T-slot extrusion to mount guide wheels for use with QTD double-edge track assembly
- **QuickTrak®** wheel bushings made from 303 stainless steel have large flanges to span T-slot openings and have a slot to capture the wheel cover
- Wheel covers with lubricating wiper foams snap-fit onto the wheel bushing slot and attach to the T-bar with nylon bolts
- Includes a bottle of lubricating oil and all required hardware

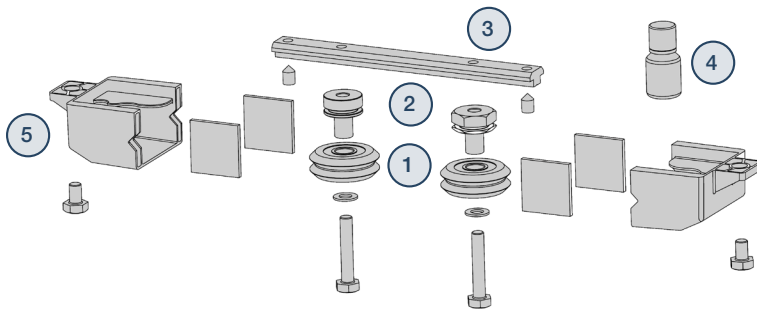

### Key Kit Contents:

- 1 DualVee® wheels
- 2 AISI 303 stainless steel bushings (1 eccentric, 1 concentric)
- 3 T-bar
- 4 Bottle of lubrication oil
- 5 Snap-on wheel covers with track-wiping foam

PART NUMBER	DESCRIPTION	UNITS
QTD2WK	Wheel Kit for <b>QuickTrak®</b> Double-Edge Size 2	ea
QTD3WK	Wheel Kit for <b>QuickTrak®</b> Double-Edge Size 3	ea

# Double-Edge Brake Kit

## Product Features

- Kits contain all parts needed to add a manual position locking brake to wheel plate assemblies
- Brake calipers flex to contact the track assemblies for holding wheel plate position
- Compatible with the edge T-slots on **QuickTrak®** wheel plate extrusions
- Includes adjustable position handle and an adjustment gage for setting the proper gap between the caliper and the track
- QTD version has standard thread rod length and is compatible with QTD assemblies

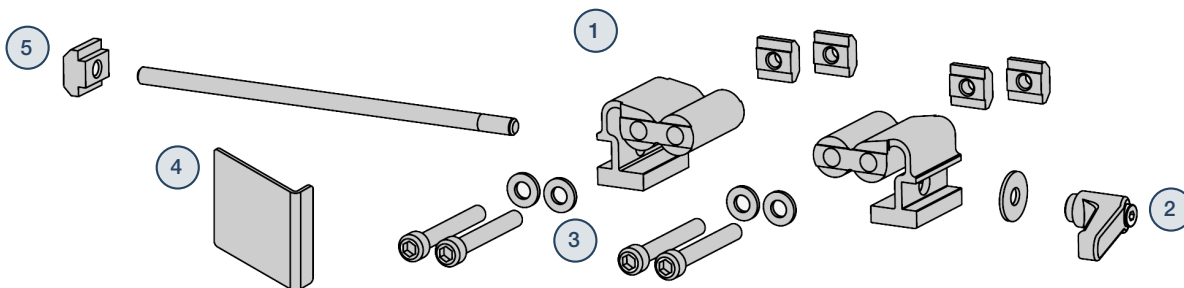

PART NUMBER	DESCRIPTION	UNITS
QTD2BK	Brake Kit for <b>QuickTrak®</b> Double-Edge Size 2	ea
QTD3BK	Brake Kit for <b>QuickTrak®</b> Double-Edge Size 3	ea

### Key Kit Contents:

- 1 Brake calipers, hard anodized 6063-T6 aluminum
- 2 Manual, adjustable-position handle
- 3 Mounting fasteners, washers and T-nuts
- 4 Installation adjustment gage
- 5 Threaded rod and T-nut



# Application Example

This assembly depicts how a customized **QuickTrak®** system is being used to move a coating applicator back and forth onto printed materials. The ease of installation and durable motion of **DualVee Motion Technology®** in the **QuickTrak®** system proved to be the ideal linear guide solution.

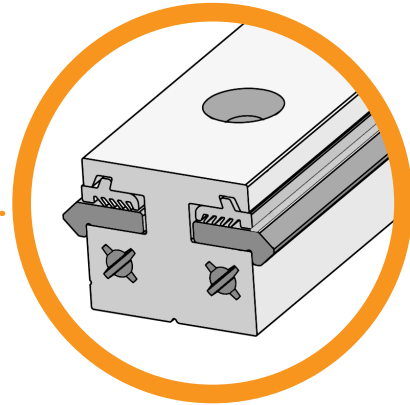
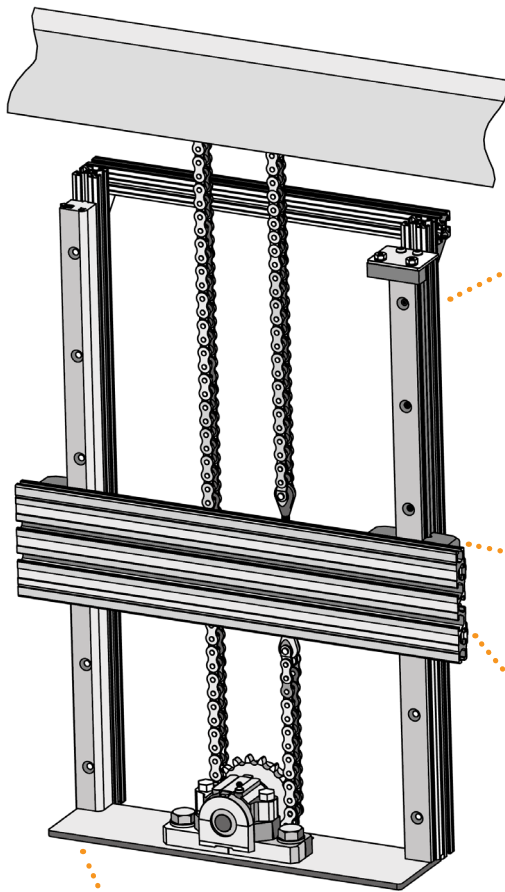

**QuickTrak®** double-edge track assembly

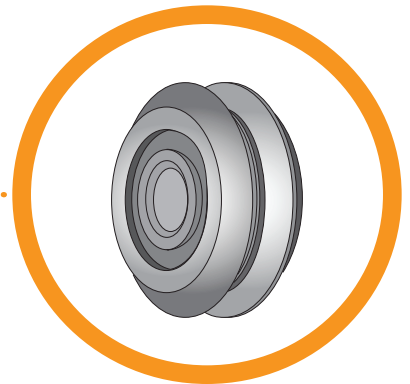

**QuickTrak®** wheel kits with **DualVee®** guide wheels and wheel covers

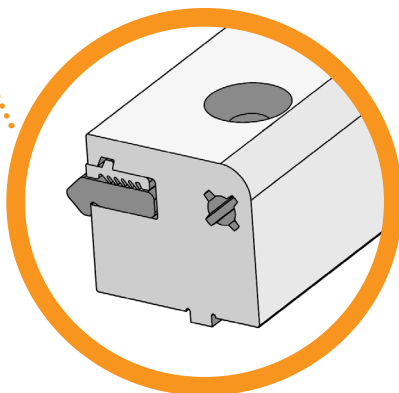

**QuickTrak®** single-edge track assembly

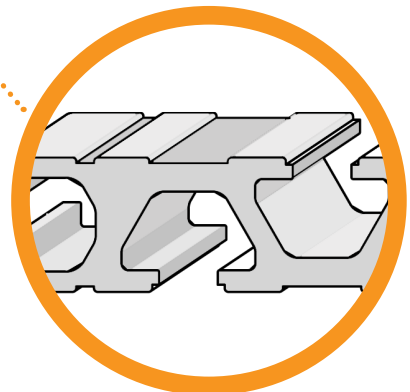

**QuickTrak®** wheel plate extrusion

# Single-Edge Systems

## System Specifications

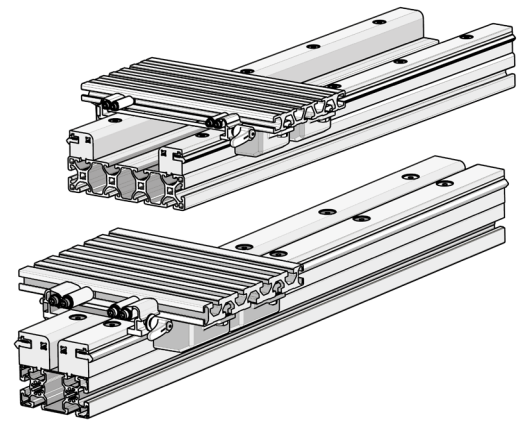

- Load capacity of single-edge QTS2 and QTS3 is dependent upon the user configured wheel plate span and resulting wheel spacing
- Utilizing **DualVee®** wheels and track sizes 2 and 3
- See the complete **DualVee Motion Technology®** catalog for further wheel and track details
- Mounts to T-slot aluminum extrusion or slotted surface
- Available with optional brake kits

PART NUMBER	DESCRIPTION	UNITS
QTS2 _____*	System assembly — <b>QuickTrak®</b> Single-Edge Size 2	ea
QTS3 _____*	System assembly — <b>QuickTrak®</b> Single-Edge Size 3	ea

\* Final part number is assigned by BWC; please call

DESCRIPTION		QTS2, SIZE 2		QTS3, SIZE 3		
		(inches)	(millimeters)	(inches)	(millimeters)	
Standard T-Slot Spacing (BTS) on Single Beam		1.5, 3.0, 4.5	30, 40, 50, 60, 75, 80, 90, 120	1.5, 3.0, 4.5	40, 45, 50, 60, 80, 90, 100, 120, 135, 150, 225, 315	
WHEEL PLATE & BRAKE DIMENSIONS	Mounting Beam T-Slot Spacing	BTS	User specified T-slot spacing			
	Wheel Spacing Width	A	BTS + 2.668	BTS + 67.77	BTS + 3.826	BTS + 97.18
	Wheel Plate Width (Min.)	B	BTS + 5.421	BTS + 137.7	BTS + 7.795	BTS + 198
	Mounting Surface to Wheel Cover	C	0.066	1.67	0.111	2.81
	Wheel Plate Length	D	5.118	130	7.087	180
	Wheel Spacing Length	E	2.953	75	3.543	90
	Wheel Plate Height	F	2.000	50.79	2.553	64.85
	Wheel Plate T-Slot End	G	1.821	46.25	0.886	22.5
	Wheel Plate T-Slot Spacing	H	1.476	37.5	1.772	45
	Wheel Plate Thickness	J	0.738	18.75	0.886	22.5
	Brake Kit Length	K	1.260	32	1.730	43.95
	Brake Kit Maximum Length	M	2.284	58.01	2.475	62.87
	Mounting Beam T-slot to Brake End	N	1.425	36.2	2.247	57.07
	Mounting Beam T-slot to Brake Handle	P	2.449	62.2	3.114	79.1
TRACK	Track Assembly Length	L	TRAVEL + D + K		TRAVEL + D + K	

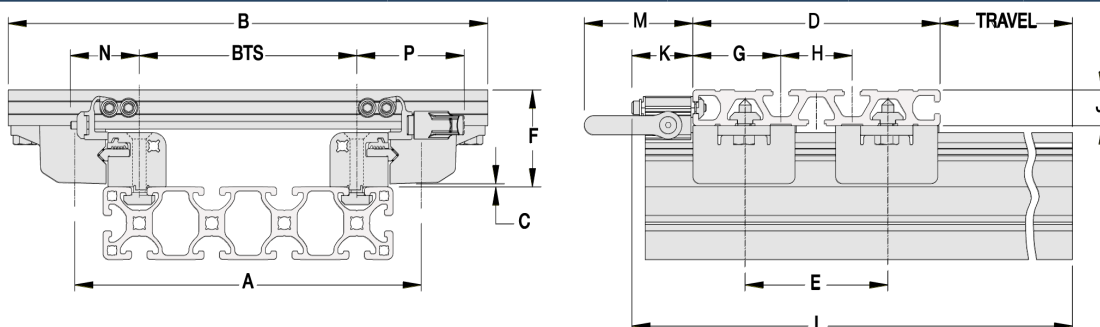

# Single-Edge Track Assemblies

## Product Features

- Mount track over any T-slot aluminum extrusion or slotted surface quickly and easily with simple hand tools and common fasteners
  - Size 2 designed for 8mm T-slots and M6 flat head screws
  - Size 3 designed for 10mm T-slots and M8 flat head screws
- The locating tab feature on the bottom surface allows for precise alignment
- Patented track clamp wedge with flexible fingers permanently holds the steel track without adhesives
- Made from clear anodized 6063 aluminum with hardened and polished AISI 1045 carbon steel **DualVee®** track (53 HRc minimum)
- Supplied permanently assembled and cut to length up to 6m maximum

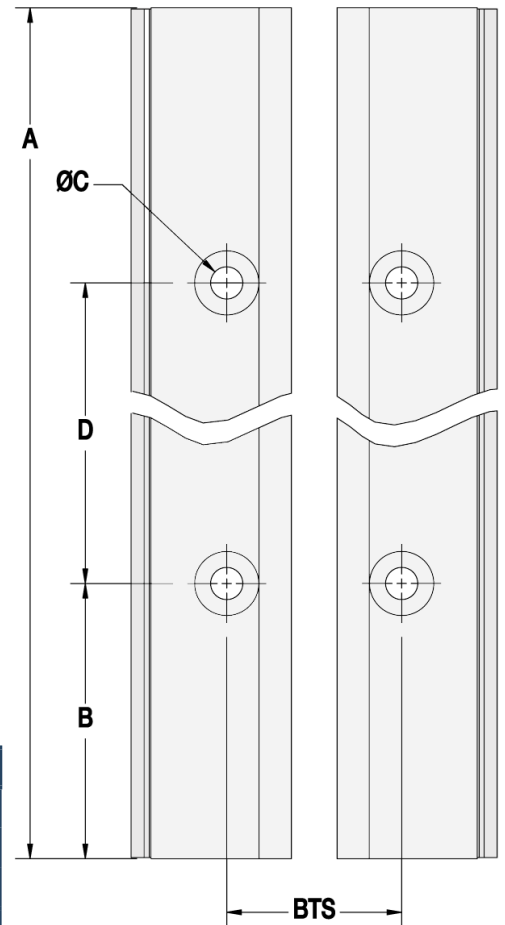
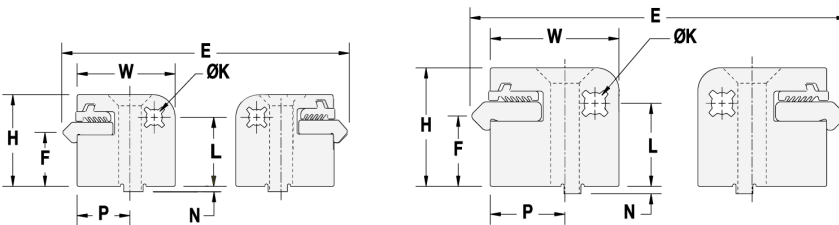

PART NUMBER	DESCRIPTION	UNITS
QTS2TA	Track Assembly — <b>QuickTrak®</b> Single-Edge Size 2	meter
SHFLM6X35SS	Mounting Screw — Flat Head M6 x 35mm stainless	ea
12421026	Mounting T-nut — M6 thread for 8mm T-slot	ea
QTS3TA	Track Assembly — <b>QuickTrak®</b> Single-Edge Size 3	meter
SHFLM8X45SS	Mounting Screw — Flat Head M8 x 45mm stainless	ea
12421002	Mounting T-nut — M8 thread for 10mm T-slot	ea

DESCRIPTION			QTD2TA—SIZE 2		QTD3TA—SIZE 3	
			(inches)	(millimeters)	(inches)	(millimeters)
TRACK ASSEMBLY DIMENSIONS	Track Assembly Length	A	specify length per meter up to 6.0 maximum			
	Track Assembly End Spacing	B	$(A - \# \text{ of D spaces} \times D) / 2$		$(A - \# \text{ of D spaces} \times D) / 2$	
	Track Assembly Mounting Hole Diameter	C	0.272	6.9	0.348	8.84
	Track Assembly Mounting Hole Spacing	D	4.724	120	5.906	150
	Vee Spacing Width	E	BTS + 1.668	BTS + 42.37	BTS + 2.326	BTS + 59.08
	Vee Spacing Height	F	0.656	16.66	0.857	21.77
	Track Assembly Height	H	1.118	28.4	1.444	36.68
	Track Assembly Width	W	1.201	30.5	1.576	40
	Track Assembly End Hole Diameter	K	0.197	5	0.266	6.8
	Track Assembly End Hole Height	L	0.842	21.39	1.011	25.68
	Track Assembly Bottom Tab	N	0.065	1.65	0.09	2.3
	Track Assembly Offset	P	0.647	16.43	0.913	23.19

# Single-Edge Wheel Mounting Kits

## Product Features

- Kits contain all parts needed to assemble your own wheel plate onto T-slot aluminum extrusions (recommended 2 kits per assembly)
- Insert T-bar into T-slot extrusions at custom span lengths to mount guide wheels (See wheel plate extrusion sold per meter on page 10)
- **QuickTrak®** wheel bushings made from 303 stainless steel have large flanges to span T-slot openings and have a slot to capture the wheel cover
- Wheel covers with lubricating wiper foams snap-fit onto the wheel bushing slot and attach to the T-bar with nylon bolts
- Includes a bottle of lubricating oil and all required hardware

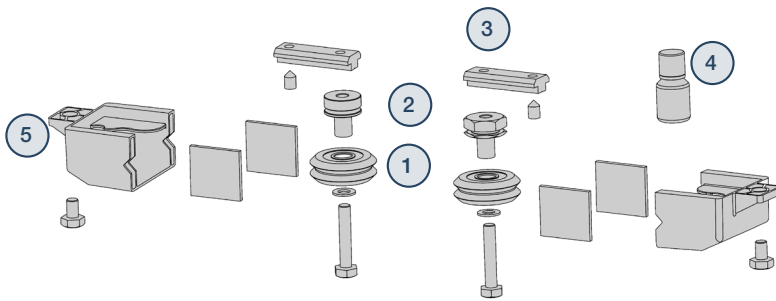

### Key Kit Contents:

- 1 DualVee® wheels
- 2 AISI 303 stainless steel bushings (1 eccentric, 1 concentric)
- 3 T-bars
- 4 Bottle of lubrication oil
- 5 Snap-on wheel covers with track-wiping foam

PART NUMBER	DESCRIPTION	UNITS
QTS2WK	Wheel Kit for <b>QuickTrak®</b> Single-Edge Size 2	ea
QTS3WK	Wheel Kit for <b>QuickTrak®</b> Single-Edge Size 3	ea

# Single-Edge Brake Kit

## Product Features

- Kits contain all parts needed to add a manual position locking brake to wheel plate assemblies
- Brake calipers flex to contact the track assemblies for holding wheel plate position
- Compatible with the edge T-slots on **QuickTrak®** wheel plate extrusions
- Includes adjustable position handle and an adjustment gage for setting the proper gap between the caliper and the track
- QTS version has custom length thread rod up to 1 m long to accommodate various track assembly spans

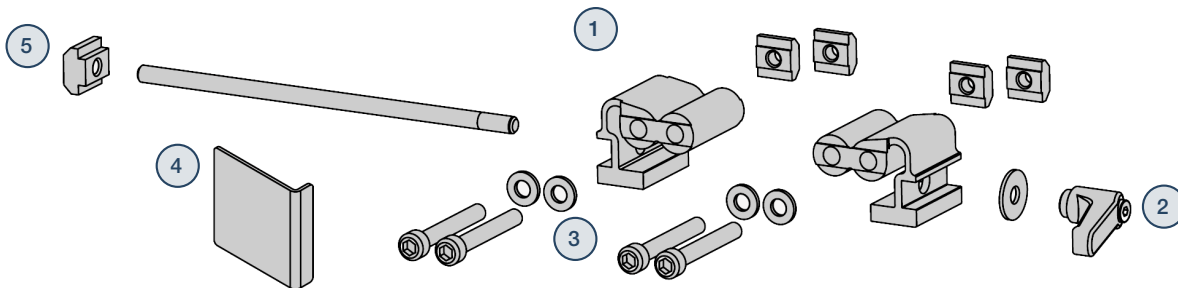

### Key Kit Contents:

- 1 Brake calipers, hard anodized 6063-T6 aluminum
- 2 Manual, adjustable-position handle
- 3 Mounting fasteners, washers and T-nuts
- 4 Installation adjustment gage
- 5 Threaded rod and T-nut

PART NUMBER	DESCRIPTION	UNITS
QTS2BK	Brake Kit for <b>QuickTrak®</b> Single-Edge Size 2	ea
QTS3BK	Brake Kit for <b>QuickTrak®</b> Single-Edge Size 3	ea

# Wheel Plate Extrusion

## Product Features

- Low profile and wide extrusion is designed for use as wheel plates and structural support
- T-slots on the bottom surface for attaching **QuickTrak®** wheel kits, T-slots on the side surfaces for attaching **QuickTrak®** brake kits, and T-slots on the top surface for attaching to equipment
- Made from 6063 aluminum with clear hard anodized coating
- Available cut to standard lengths for **QuickTrak®** double-edge systems or cut to any length up to 3.0 meters for **QuickTrak®** single-edge
- Assemble linear motion systems quickly with simple hand tools

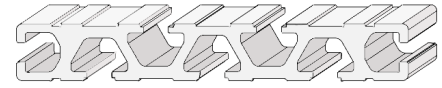

Size 2 wheel plate extrusion

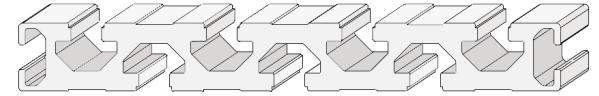

Size 3 wheel plate extrusion

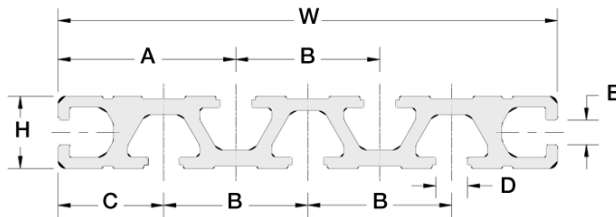

PART NUMBER	DESCRIPTION	UNITS
QT2WPE	Wheel Plate Extrusion Size 2	meter
QTD2WPE	Wheel Plate for <b>QuickTrak®</b> Double-Edge Size 2	ea

\* QTD2WPE standard cut length is 5.354 in (136 mm)

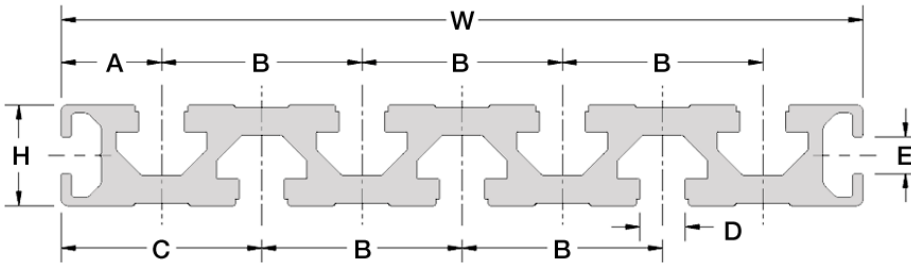

PART NUMBER	DESCRIPTION	UNITS
QT3WPE	Wheel Plate Extrusion Size 3	meter
QTD3WPE	Wheel Plate for <b>QuickTrak®</b> Double-Edge Size 3	ea

\* QTD3WPE standard cut length is 7.717 in (196 mm)

**KEY FEATURE**  
Quick and easy mounting to your application

**KEY FEATURE**  
Wheel mounting location is adjustable by user without drilling

DESCRIPTION		QT2WPE—SIZE 2		QT3WPE—SIZE 3	
		(inches)	(millimeters)	(inches)	(millimeters)
Wheel Plate Thickness	H	0.738	18.75	0.866	22.50
Wheel Plate Width	W	5.118	130.00	7.087	180.00
Wheel Plate Top T-Slot to End	A	1.821	46.25	0.886	22.50
Wheel Plate T-Slot Spacing	B	1.476	37.50	1.772	45.00
Wheel Plate Bottom T-Slot to End	C	1.083	27.50	1.772	45.00
Wheel Plate T-Slot Opening	D	0.325	8.26	0.402	10.20
Wheel Plate Edge T-Slot Opening	E	0.248	6.30	0.323	8.20

# How to Order

Questions? Please call us directly: **888.580.8272** | email: **info@bwc.com**

	PART NUMBER	DESCRIPTION	UNITS	QUANTITY
TRACK ASSEMBLY	QTD2TA	Track Assembly, Double-Edge, Size 2	meter	up to 6m
	QTD3TA	Track Assembly, Double-Edge, Size 3	meter	up to 6m
	QTS2TA	Track Assembly, Single-Edge, Size 2	meter	up to 6m
	QTS3TA	Track Assembly, Single-Edge, Size 3	meter	up to 6m
	SHFLM6X35SS	Mounting Screw, Size 2, Flat head M6 x 35mm stainless	each	each
	SHFLM8X45SS	Mounting Screw, Size 3, Flat head M8 x 45 mm stainless	each	each
	12421026	Mounting T-nut, Size 2, 8mm T-slot with M6 thread	each	each
	12421002	Mounting T-nut, Size 3, 10mm T-slot with M8 thread	each	each
WHEEL PLATE EXT.	QT2WPE	Wheel Plate Extrusion Size 2	meter	up to 3m
	QT3WPE	Wheel Plate Extrusion Size 3	meter	up to 3m
	QTD2WPE	Wheel Plate Ext., Size 2 for QTD2	each	each
	QTD3WPE	Wheel Plate Ext., Size 3 for QTD3	each	each
WHEEL KITS	QTD2WK	Wheel Kit, Double-Edge, Size 2	each	each
	QTD3WK	Wheel Kit, Double-Edge, Size 3	each	each
	QTS2WK	Wheel Kit, Single-Edge, Size 2	each	each
	QTS3WK	Wheel Kit, Single-Edge, Size 3	each	each
BRAKE KITS	QTD2BK	Brake Kit, Double-Edge, Size 2	each	each
	QTD3BK	Brake Kit, Double-Edge, Size 3	each	each
	QTS2BK	Brake Kit, Single-Edge, Size 2	each	each
	QTS3BK	Brake Kit, Single-Edge, Size 3	each	each
SYSTEM ASSEMBLIES	QTD2	Wheel Plate Assembly, Size 2 QTD	each	each
	QTD2 with Brake	Wheel Plate Assembly, Size 2 QTD	each	each
	QTD3	Wheel Plate Assembly, Size 3 QTD	each	each
	QTD3 with Brake	Wheel Plate Assembly, Size 3 QTD	each	each
	QTS2	Wheel Plate Assembly, Size 2 QTS	each	each
	QTS2 with Brake	Wheel Plate Assembly, Size 2 QTS	each	each
	QTS3	Wheel Plate Assembly, Size 3 QTS	each	each
	QTS3 with Brake	Wheel Plate Assembly, Size 3 QTS	each	each
HARDWARE	12421022	T-nut for 6mm T-slot with M3 thread	each	each
	12421023	T-nut for 6mm T-slot with M4 thread	each	each
	12421024	T-nut for 6mm T-slot with M4 thread	each	each
	12421025	T-nut for 6mm T-slot with M5 thread	each	each
	12421026	T-nut for 6mm T-slot with M6 thread	each	each
	12421029	T-nut for 6mm T-slot with M4 thread	each	each
	12421030	T-nut for 10mm T-slot with M5 thread	each	each
	12421001	T-nut for 10mm T-slot with M6 thread	each	each
	12421002	T-nut for 10mm T-slot with M8 thread	each	each

# Product Summary

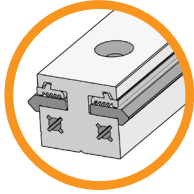

## Track Assemblies

QTD and QTS track assemblies allow an end user to quickly and easily mount linear guide wheel motion components onto aluminum T-slot extrusions from any manufacturer with simple hand tools and common fasteners.

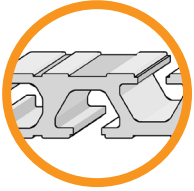

## Wheel Plate Extrusions

Inexpensive, recyclable, 6063 aluminum, corrosion resistant, easy to cut to length, flexible mounting applications, compatible with other commercially available T-slot hardware.

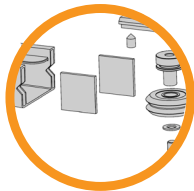

## Wheel Kits

The kit provides all of the parts and supplies for mounting wheels to a T-slot extruded aluminum wheel plate including wheels, bushings, wheel covers, lubricating foams and oil, and mounting hardware. These kits make it convenient for the end user to order and assemble QuickTrak linear guides.

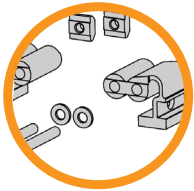

## Brake Kits

The kit provides all of the parts and supplies for mounting a brake to a T-slot extruded aluminum wheel plate including brake calipers, adjustment gage, handle, threaded rod, and all of the necessary bolts, washers and T-nuts. The brake kit can be used to allow position locking of the wheel plate on the track at any location along the travel length of the system.

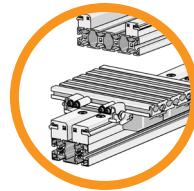

## System Assemblies

Easily mountable, already assembled, durable, long-lasting, highly efficient.

## T-slot Extrusion Profiles

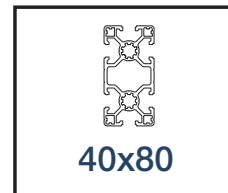
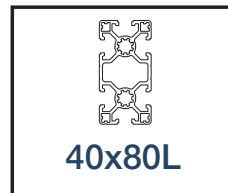
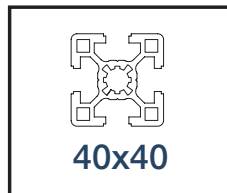
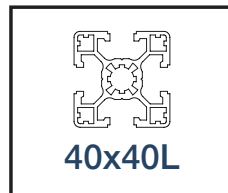
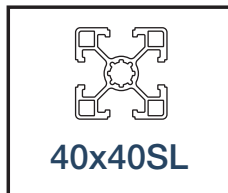

\* Commonly used extrusion profiles are shown above

**For aluminum extrusions and connection hardware, see the MCS Catalog:**

<http://www.bwc.com/products/mcs.html>

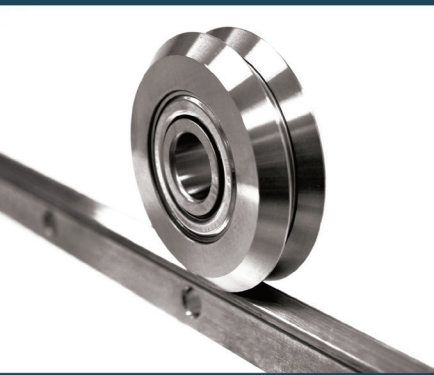

**Bishop-Wisecarver Corporation** is a WBENC certified woman-owned manufacturer of the original **DualVee®** guide wheel and industry leader in linear and curvilinear motion solutions. Exclusive North and Central American partner and distributor for **HepcoMotion®** products since 1984.

- DualVee®** Guide Wheels
- LoPro®** Linear Motion System
- MadeWell®** Crown Rollers
- MadeWell®** Radial Wheels
- MinVee®** Linear Slide System
- UtiliTrak®** Linear Motion Guide
- UTCSK** Camera Slider Kit
- QuickTrak®** Modular Linear Guide Kit

- HepcoMotion®**
- ALR Aluminum Rings
  - DAPDU2 Double Acting Profile Driven Unit
  - DLS Driven Linear System
  - DTS2 Driven Track System
  - GV3 Linear Guidance and Transmission System
  - HDCB Heavy Duty Compact Beam
  - HDCS Heavy Duty Compact Screw
  - HDLS Heavy Duty Driven Linear System
  - HDRT Heavy Duty Ring Slides and Track System
  - HDS2 Heavy Duty Slide System
  - MHD Heavy Duty Track Roller Guidance System
  - MCS Machine Construction System
  - PDU2 Profile Driven Unit
  - PDU2M Belt Driven Unit
  - PRT2 Precision Ring and Track System
  - PSD80 Screw Driven Linear Actuator
  - PSD120 Profile Screw Driven Unit
  - SBD Sealed Belt Drive
  - Simple-Select®
  - SL2 Stainless Steel Based Slide System

### 3D CAD DRAWINGS

Download files at [www.bwc.com/3dcad.php](http://www.bwc.com/3dcad.php)

### FOLLOW BISHOP-WISECARVER NEWS & UPDATES

Twitter at [www.twitter.com/bwcnews](https://www.twitter.com/bwcnews)

### PRODUCT ORDERS

Please call **Bishop-Wisecarver Corporation** at **888.580.8272** with your specific application requirements — our technical staff will be available to assist with your custom solution.

Complete terms, conditions and warranty information is available at [www.bwc.com/about\\_conditions.vp.html](http://www.bwc.com/about_conditions.vp.html)

### WHAT MAKES US DIFFERENT

Our engineering and manufacturing facility provides expert development support and quick turnaround time. We tackle all engineering challenges with a novel approach — we have the patents to prove it and are majority sourced USA. We offer custom engineering services and technical expertise in motion, sensor and actuator integration, real-time software development, and electromechanical modeling and design.

### INDUSTRIES SERVED

- Aerospace & Defense
- Aircraft & Automotive
- Architecture
- Consumer Products
- Conveying Equipment
- Electronics
- Entertainment
- Fabrication
- General Automation
- Industrial Equipment
- Instrumentation
- Lab Automation
- Liquid Handling
- Machine Tool
- Material Handling & Packaging
- Medical Device Manufacturing
- Powertransmission & Railway
- Printing Machinery
- Printed Circuit Assembly
- Research & Development
- Relay & Industrial Controls
- Radio & TV Broadcasting
- Robotics, Semi-Conductor
- Food & Beverage
- Surgical Equipment
- Transportation
- Welding & Soldering
- Wood Processing