

HepcoMotion® ALR

Aluminum Rings for Lighter Load Applications

NEW!

*Rings Weigh **Up to 54% Less**
than Steel Rings of Comparable Size!*

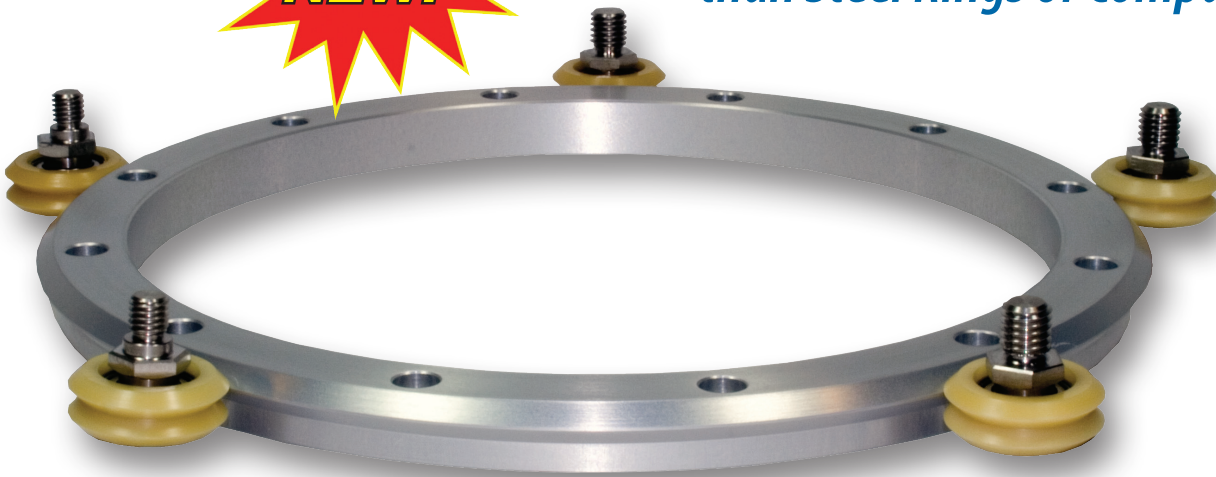

KEY FEATURES:

- HepcoMotion ALR aluminum rings run with Bishop-Wisecarver's DualVee® polymer guide wheels
- Rings are made from anodized aluminum
- Available in 4 standard sizes from 148mm to 300mm in diameter
- Compatible with Size 2 DualVee wheels. For smaller, lighter applications, Size 0 and Size 1 DualVee wheels can be specified
- Guide wheels are comprised of a polymer outer form molded onto a stainless steel bearing and stud
- A cost-effective rotary movement system for medium precision, light load applications
- Suitable for use in applications that require a non-magnetic environment
- Suitable for use in applications requiring corrosion resistance

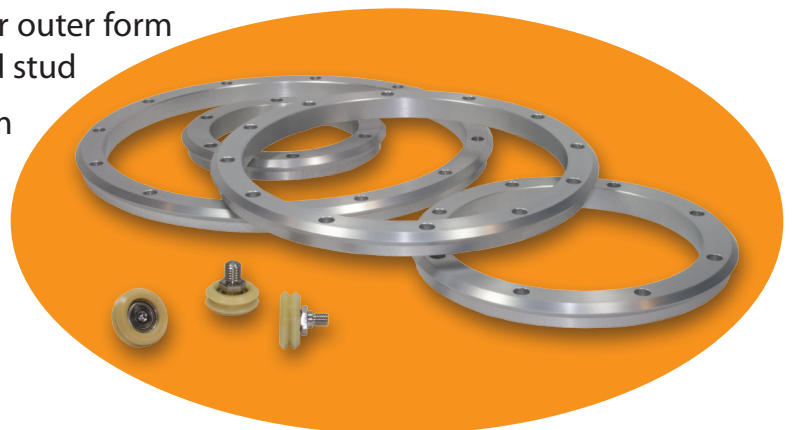

Data and Dimensions

ALR Rings are machined from high strength aluminum alloy and are anodized which gives an excellent combination of durability and corrosion resistance, and has an attractive finish.

This surface is optimized to run with Bishop-Wisecarver DualVee polymer guide wheels. Stronger DualVee steel wheels will also fit, but their use is not generally recommended due to ring wear. Please contact Bishop-Wisecarver for details.

The four sizes of ring shown below are standard items. Other configurations and sizes are also possible - see page 4.

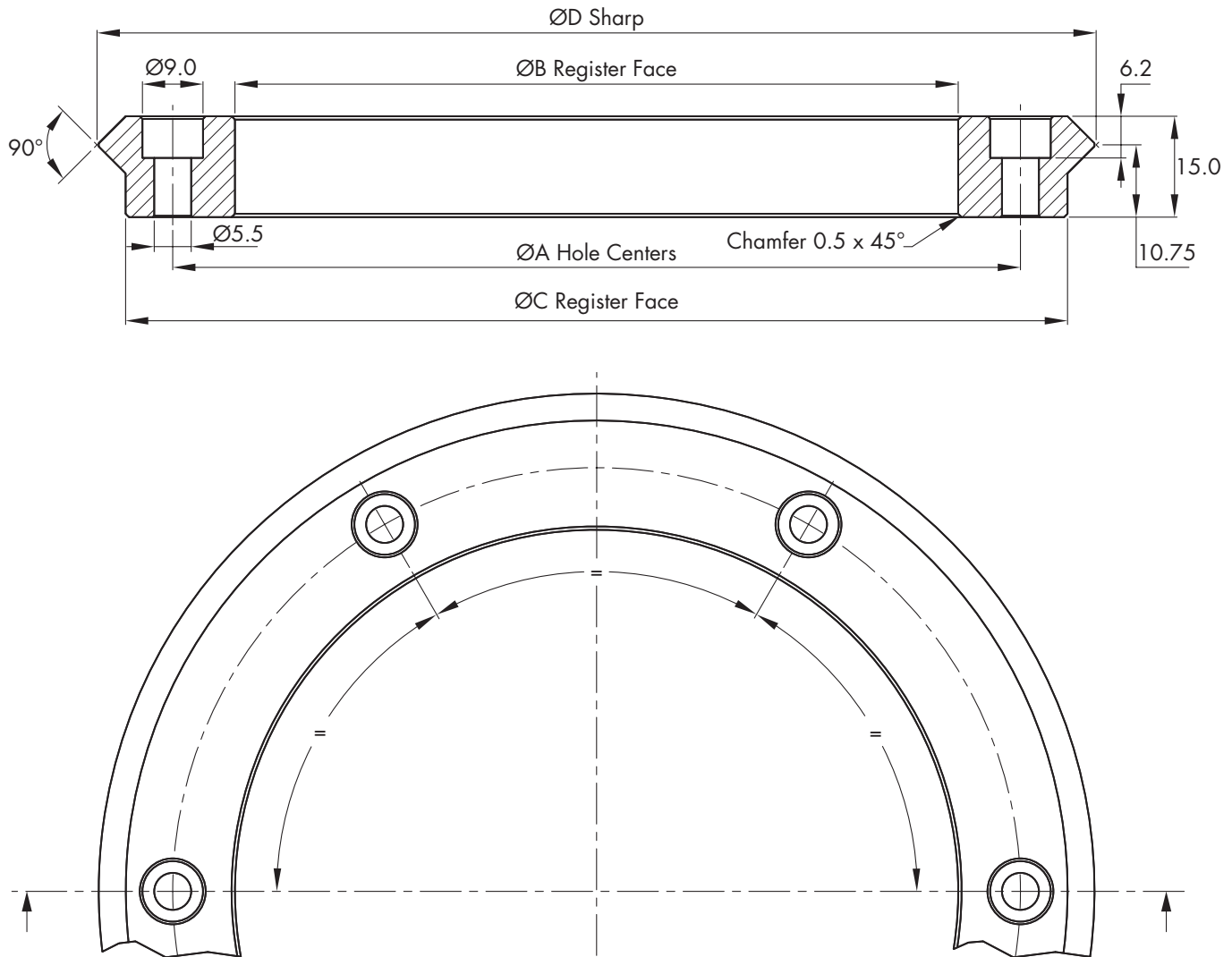

Part Number	ØA	ØB	ØC	ØD	Number of Holes	Weight (g)
ALR148	126	107.5	140	148.5	6	270
ALR199	175	157.5	191	199.5	8	390
ALR250	228	210	242	250.5	12	480
ALR300	278	260	292	300.5	12	590

DualVee Polymer Overmolded Wheels

Bishop-Wisecarver polymer overmolded wheels with integral studs are perfectly matched for use with ALR Rings.

The outer portion of the wheels are precisely moulded in a high performance engineering plastic which runs smoothly and with little friction or wear on the ring Vees. All metal parts of the wheels are stainless steel.

The bearings in the wheels are shielded, and are lubricated for life internally.

The size 2 wheels (SWIC2P & SWIE2P) are the usual choice for use with all the ALR rings in the standard range shown on page 2, but the smaller size 1 and size 0 wheels will also fit.

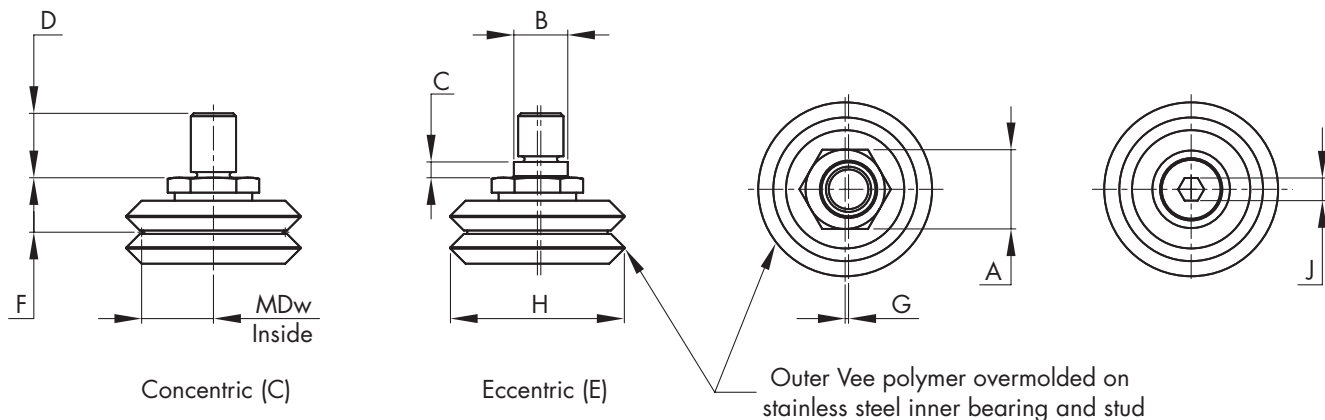

Wheel Part Number		A	ØB ±0.05	C ±0.13	D ±0.1	E	F ±0.05	G	MD _w Inside
Concentric	Eccentric								
SWIC2P	SWIE2P	14	9.53	2.79	11.38	26.57	9.63	0.93	12.70
SWIC1P	SWIE1P	12	6.35	2.16	8.10	19.34	7.30	0.83	7.95
SWIC0P	SWIE0P	11	5.56	2.16	7.62	16.94	6.15	0.81	5.94

Wheel Part Number		Concentric Stud Thread	Eccentric Stud Thread	ØH	J	Weight (g)	Load Capacity/N	
Concentric	Eccentric						Radial	Axial
SWIC2P	SWIE2P	M10 x 1.5	M8 x 1.25	30.73	4	26	70	42
SWIC1P	SWIE1P	M8 x 1.25	M6 x 1.0	19.58	-	11	55	27.5
SWIC0P	SWIE0P	M6 x 1.0	M5 x 0.8	14.83	-	6	28	12

For best load capacity and life, it is recommended that the contact points between wheels and ring are lubricated. This can be effected using DualVee Lubricator Assemblies (see page 16 of the full line DualVee catalog available at www.bwc.com/products/dual-vee.html).

The nominal lives of each wheel at the load capacities stated in the table are 87km, 55km and 41km for the size 2, 1 & 0 wheels respectively.

The system life is determined by the most heavily loaded wheel, and the this can be calculated using the methods detailed in pages 23-24 of the DualVee catalog at the web address above.

The Hepco PRT2 catalog (available at www.bwc.com/products/prt.html) pages 55 to 56 includes calculations which will be helpful in determining the loads on the wheels in an ALR ring based system.

Special Rings

For batches of components, other forms of aluminum or steel ring can be supplied. These include other diameters and thicknesses, rings with internal vees, gearcut rings, and rings machined in the form of self-aligning timing belt pulleys (see below). Please contact Bishop-Wisecarver for full details of capability.

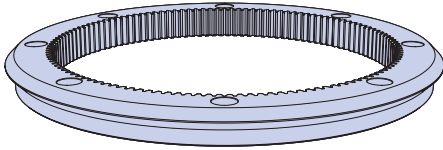

Gearcut Ring - Steel

Standard range can accommodate
MOD1.25 gears.

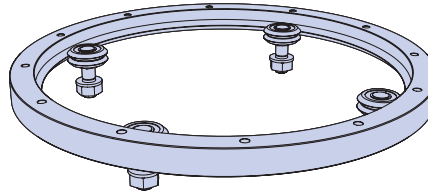

**Rings with Internal Vee
- Aluminum or Steel**

Can be made on request.

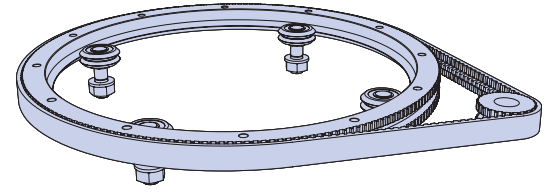

Timing Pulley Ring - Steel

Rings with an internal Vee can be
machined to suit self-aligning belts,
and be supplied with belts and pulleys.

Bishop-Wisecarver Corporation is a woman-owned manufacturer of the original DualVee® guide wheel and industry leader in guided motion technology. We are the exclusive North and Central American partner and distributor for HepcoMotion products since 1984.

BISHOPWISECARVER®

Bishop-Wisecarver

DualVee® Guide Wheels
LoPro® Linear Motion System
MadeWell® Crown Rollers
MinVee® Linear Slide System
QuickTrak® Slide System
UtiliTrak® Linear Motion Guide
UTCSK Camera Slider Kit



HepcoMotion®

DAPDU2 Double Acting Profile Driven Unit
DLS Driven Linear System
DTS Driven Track System
GV3 Linear Guidance and Transmission System
HDCB Heavy Duty Compact Beam
HDCS Heavy Duty Compact Screw
HDLS Heavy Duty Driven Linear System
HDRT Heavy Duty Ring Slides and Track System
HDS2 Heavy Duty Slide System
MHD Heavy Duty Track Roller Guidance System
MCS Machine Construction System
PDU2 Profile Driven Unit
PDU2M Belt Driven Unit
PRT2 Precision Ring and Track System
PSD80 Screw Driven Linear Actuator
PSD120 Profile Screw Driven Unit
SBD Sealed Belt Drive
Simple-Select®
SL2 Stainless Steel Based Slide System

Connect with us online! Watch our videos on <http://youtube.com/BishopWisecarver> or <http://vimeo.com/BishopWisecarver>. Also, friend us at <http://www.facebook.com/BishopWisecarver> or follow us on Twitter @BWCnews.

3D CAD DRAWINGS

Download 3D CAD files for our complete product line at www.bwc.com/3dcad.php.

FOLLOW BISHOP-WISECARVER NEWS & UPDATES

on Blogger <http://bwcnews.blogspot.com/>

PRODUCT ORDERS

Please call Bishop-Wisecarver with your specific application requirements. Our technical staff is available to assist with your custom solution.

Bishop-Wisecarver provides a written three year limited warranty on our Swiss bearings and a written one year limited warranty on all other products assuring the customer that its products conform to published specifications and are free from defects in material or workmanship

Complete terms and conditions and warranty information is available at http://www.bwc.com/about_conditions.vp.html.

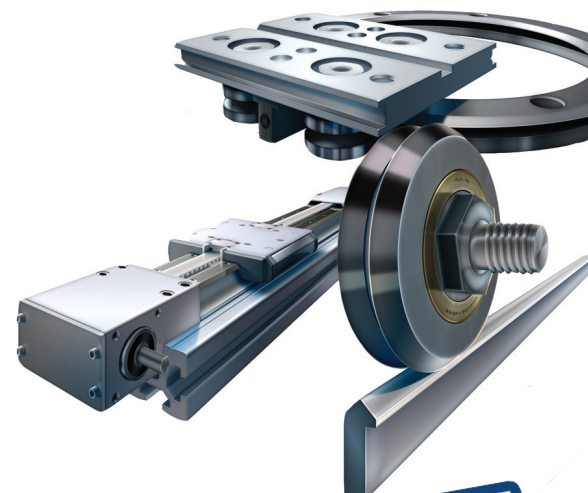

Scan this QR barcode
on your mobile
phone to watch the
HD demo video!



888.580.8272

925.439.8272

www.bwc.com