

## MadeWell® Radial Wheel: A Low Cost Solution for Unique Linear Guide Wheel Applications

By: Brian Burke, Project Engineer at Bishop-Wisecarver Corporation®

Many industrial applications of linear guides require substantial load capacity in a variety of orientations to properly withstand complex and dynamic forces. These forces originate from a variety of sources including the force of gravity, moving masses, accelerations and resistance to motion caused by cutting tools or other process requirements. The payload mass can't always be located in the ideal location directly over the linear guide wheel so a combination of radial and axial load capacity is needed for cantilever and gantry configurations. Dual-Vee guide wheels from Bishop-Wisecarver Corporation contain two rows of angular contact ball bearings and can accommodate forces in a variety of directions.

When a machine or product design can accommodate the center of the moving mass close to the centerline of the guide wheel, the load on the wheel is primarily a radial load and substantial axial load capacity is unnecessary. Specifying a linear guide wheel bearing designed with high axial load capacity for applications which do not have axial loads is wasteful.

MadeWell Radial Wheels are an answer to the need for low cost linear guide wheel applications where simplified loading conditions exist. For designs where the center of mass can be located close to the centerline of the guide wheel, Radial Wheels become the ideal solution.

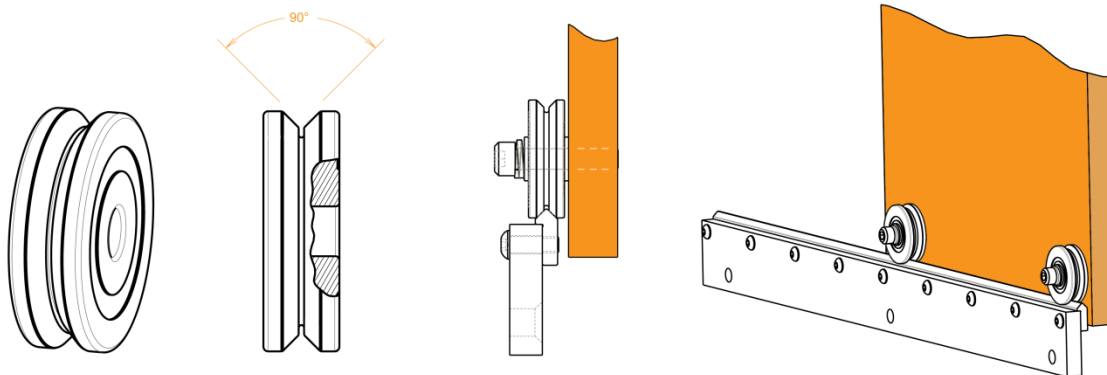

Radial Wheels are a major innovation for many industries, such as the woodworking industry, where the product can be utilized in the design of processing machinery as well as in finished goods. It is now budget-friendly to accomplish smooth and reliable motion in heavily debris-contaminated environments such as in sawdust and process grit where traditional linear bearings rapidly fail. Radial Wheels are an ideal product for processing applications such as CNC engraving, guided sawing, adjustable position jigs and fixtures, assembly workstation tools, material handling aids, machine doors and guarding, and many other production floor activities. This design is also well-suited for use in finished products such as sliding wall panels, motorized windows and doors, heavy duty drawer slide applications, adjustable furniture features, and in a multitude of other market-defining product developments.

Radial Wheels can be quickly installed on products or equipment using standard off-the-shelf fasteners and simple hand tools. They have a simplified non-adjustable concentric centerline design and can be mounted without bushings because the through-hole geometries accommodate standard inch or metric fasteners. They are commonly utilized on compliant or low stiffness applications such as on free-hanging wall panels where rigid fit-up adjustments are unnecessary. Rigid preloaded systems can be implemented with alternate

guide wheel product offerings or be accommodated by simple mechanisms external to the guide wheel such as spring tensioners or jacking screws.

Radial Wheels have a 90-degree vee groove on the perimeter and are designed to roll on matching 90-degree running surfaces. Bishop-Wisecarver offers linear guide track with 90-degree surfaces in the traditional Dual-Vee product line. This track is available with optional mounting holes, and is available in AISI 1045 carbon steel unhardened at 22-25HRc or hardened to 53 HRc minimum and AISI 420 stainless steel unhardened at 20-23 HRc or hardened to 40 HRc minimum.

Radial Wheels are available in AISI 52100 carbon steel and in AISI 440C stainless steel. Both material types share the same ball retainer cage, seal, and grease. The ball cages are made of glass reinforced nylon 6,6 and the seal is made a combination of nitrile butadiene rubber and AISI 304 stainless steel. The bearings are lubricated for life with Shell Alvania EP LF2 grease. The minimum operating temperature is -20\* C and is limited by the grease, whereas the maximum operating temperature is +100\* C and is limited by the NBR seal.

Both material types are available in three primary sizes designated as size 1, 2 and 3. The size 1 wheel has an outside diameter of 0.771" and a width of 0.274" with a 0.201" diameter bore and has a 151 lbf radial load capacity. The size 2 wheel has an outside diameter of 1.210" and a width of 0.383" with a 0.251" diameter bore and has a 337 lbf radial load capacity. The size 3 wheel has an outside diameter of 1.803" and a width of 0.551" with a 0.316" diameter bore and has an 832 lbf radial load capacity.

The MadeWell Radial Wheels are internally lubricated and sealed for life. When properly installed, and maintained, this guide wheel can provide continuous duty over a very long service life with very limited maintenance. As the wheel rolls down the mating track, the 90-degree contact angle creates a velocity gradient since the circumference of the wheel is greater at the major diameter resulting in a constant sweeping action. This self-cleaning design allows the 90-degree guide wheel to operate in heavy contamination and severe environments with little maintenance. Periodic cleaning and re-lubrication of the track surface is recommended to reduce wear and maximize usable life.

The maintenance interval will vary with the application and operating environment but in most cases the MadeWell Radial Wheel will outlive profile rail with recirculating ball carriages in debris laden environments. Because the ball bearing contact raceway surfaces are sealed internally on the guide wheel, machinery and products equipped with Radial Wheels are far less susceptible to breakdown failure in harsh contaminated environments than profile rail with exposed raceway recirculating ball carriages.

Radial Wheels provide a new lower cost alternative to profile rail and other guide technologies with a design that is simple to install, simple to understand, and extremely durable. These linear guide wheels are ideal for applications involving primarily radial loads such as in sliding windows, doors, partitions, covers, and machine guarding. This product is unique in the fact that it can be utilized in finished goods, as well as in the machinery used to produce finished goods. The quality and precision of MadeWell Radial Wheels can provide tangible improvements in customer delight on critical product features.